

Standard Aircraft Characteristics

NAVY MODEL C-1A AIRCRAFT

THIS PUBLICATION SUPERSEDES NAVAIR 00-110A-1 DATED
1 MAY 1955 IN PART AND ALL ADDENDA THERETO

PUBLISHED BY DIRECTION OF THE
COMMANDER OF THE NAVAL AIR SYSTEMS COMMAND

1 JULY 1967

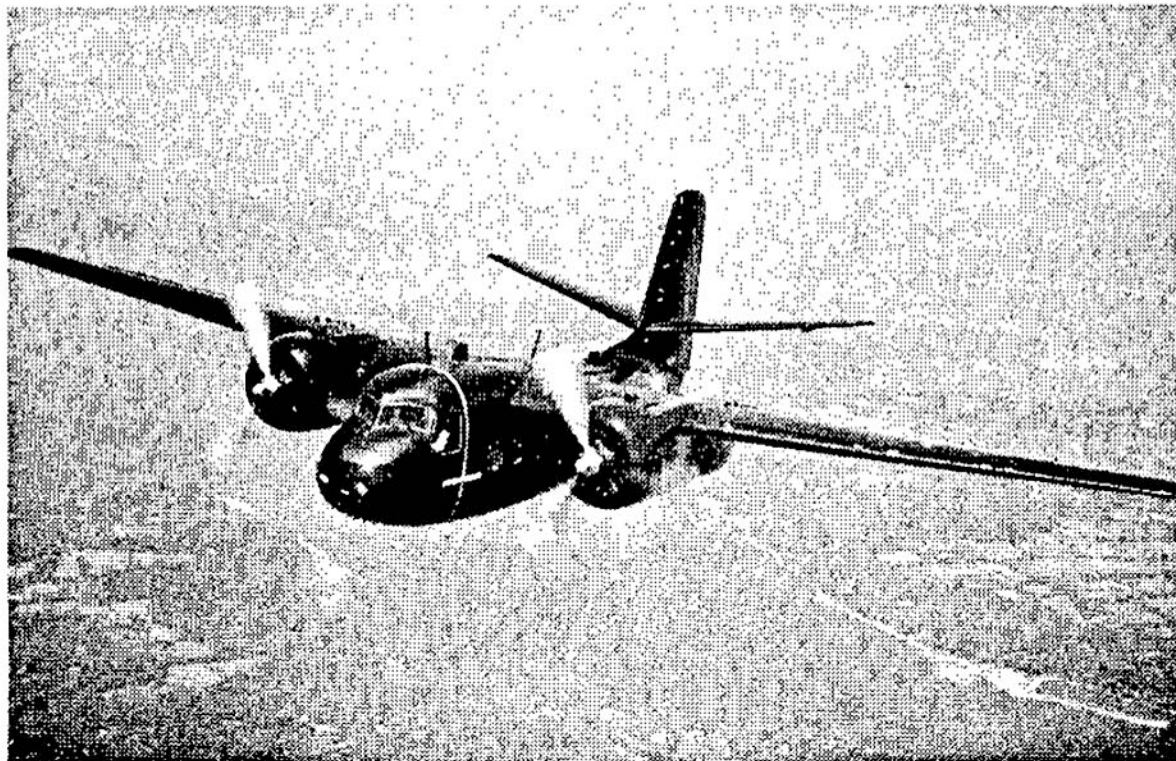

STANDARD AIRCRAFT CHARACTERISTICS

C-1A TRADER

BUREAU OF AERONAUTICS
NAVY DEPARTMENT

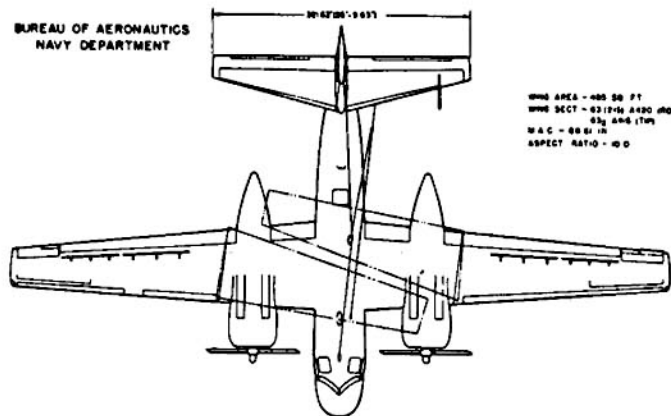

WING AREA - 400 SQ. FT.
WING SECT - 62 (1/16) A430 (ROOT)
S_{1/2} AREA 1700
W.A.C. - 60.51 IN
ASPECT RATIO - 4.0

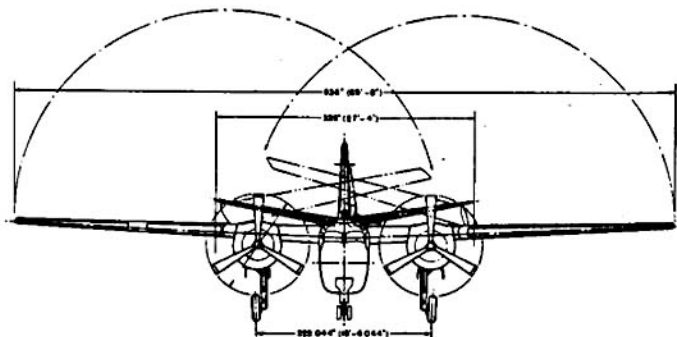

SCALE - FEET

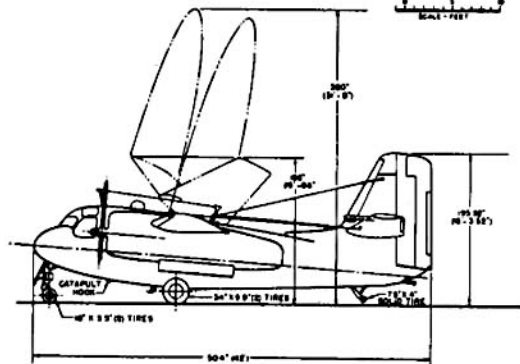

DESCRIPTIVE ARRANGEMENT
TF-1

BUREAU OF AERONAUTICS
NAVY DEPARTMENT

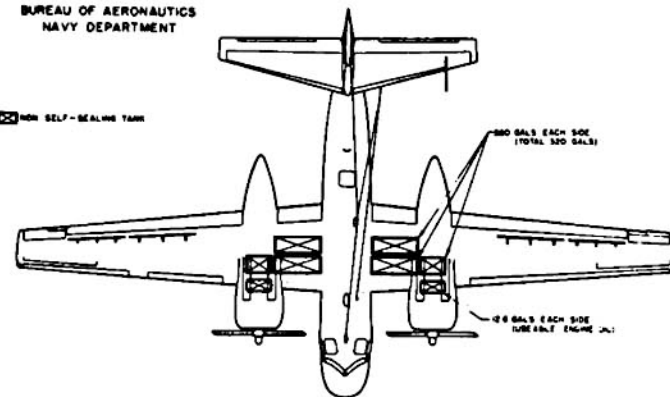

NON SELF-SEALING TANK

200 GALS EACH SIDE
(TOTAL 400 GALS)

20 G GALS EACH SIDE
1000 GALS ENGINE J.

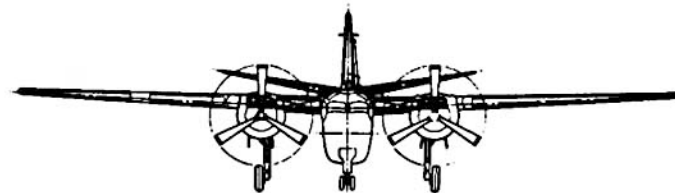

SCALE - FEET

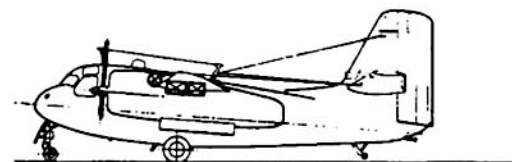

ARMAMENT & TANKAGE
TF-1

POWER PLANT

NO. & MODEL.....(2) R-1820-82
 MANUFACTURER.....Wright
 SUPERCHARGER.....1 Stage, 1 Speed
 REDUCTION GEAR RATIO.....0.5625
 PROP. MFR.....Hamilton Std.
 PROP. DESIGN NO.....6915A7(2)
 NO. BL./DIA.....3/11' - 0"

RATINGS

	BHP	RPM	ALT.
T.O.	1,525	2,800	700
MIL.	1,425	2,700	2,400
WORM.	1,275	2,500	3,500

SPEC. NO. HB67-A

MISSION AND DESCRIPTION

The TF-1 is a twin engine, eleven place, nine passenger, high wing land plane designed for use as an instrument trainer, a multi-engine trainer, a light transport or cargo aircraft, a utility or administrative aircraft and a carrier qualification trainer. It is equipped to operate under all weather conditions and is operated by a crew of two; pilot and co-pilot.

The airplane is capable of operating from CVE-105 and larger class carriers or land bases. The TF-1 can maintain a positive single engine rate-of-climb at catapult and speed.

Lateral control is provided by circular arc spoilers in conjunction with ailerons. Directional and longitudinal control is provided by conventional elevators and rudders. Directional control for single engine operation is augmented by means of a power actuated surface located between the fin and the rudder surfaces. The same surface, actuated electrically, is used as a directional trimming device. Lateral and longitudinal trim are accomplished by conventional trim tabs.

DEVELOPMENT

First Flight.....January 1955
 Service Use.....October 1955

WEIGHTS

LOADING	LBS.	L.F.
EMPTY.....	16,631.....	
BASIC.....	17,189.....	
DESIGN.....	23,031.....	3.0
MAX. T.O. (Field).....	24,600.....	
(Cat.).....	24,600.....	
MAX.LAND. (Field).....	24,600.....	
(Arrest.).....	24,200.....	

ALL WEIGHTS ARE ACTUAL.

FUEL AND OIL

NO. TANKS	GALS.	LOCATION
2	520	Wing

FUEL GRADE.....115/145
 FUEL SPEC.....Applicable MIL-F-5572

OIL

CAPACITY.....25.2
 GRADE.....1100
 SPEC.....Applicable MIL-O-6082

PERSONNEL

Transport -	
Crew	2
Pilot	
Co-pilot	
Max. passengers (seated)	9
General Cargo -	
Crew	2
Pilot	
Co-pilot	

CARGO CAPACITIES

Inside Clearances	
Length (over-all)	81'-8"
Width (maximum)	31'-7"
Height (maximum)	41'-4"
Cargo Door	
Width (maximum)	51'-7"
Height (maximum)	41'-2"
Ht. above Grd. - 3 pt.	17'-11"
Limit floor load	220 #/ '²
Maximum cargo load	3500#
Usable cubage	1165 '³

DIMENSIONS

WING AREA.....	485 sq.ft.
SPAN.....	69' - 8"
M. A. C.....	7' - 4"
LENGTH.....	42' - 0"
HEIGHT.....	16' - 3½"
TREAD.....	18' - 6"
PROP. GRD. CLEARANCE.....	1' - 0"

ELECTRONICS

UHF TRANS-RECEIVER.....ARC-27A
 HF TRANS-RECEIVER.....ARC-2A
 ICS.....AIC-8
 MARKER.....ARN-12
 ADF.....ARN-6
 IFF.....APX-6B
 ALTIMETER.....APH-22
 UHF DF.....ARA-25
 NAV. TRANS-RECEIVER.....ARN-21
 VHF NAV. SECVR. (Vor).....ARN-14A
 VHF TRANS-RECEIVER.....ARC-1

PERFORMANCE SUMMARY

TAKE-OFF LOADING CONDITION		(1)	(2)			
		TRANSPORT	GENERAL CARGO			
TAKE-OFF WEIGHT	lb.	22,789	24,579			
Fuel	lb.	3,120	3,120			
Fayload	lb.	1,710	3,500			
Wing loading	lb./sq.ft.	48	51			
Stall speed - power-off	kn.	78.3	81.4			
Take-off run at S.L. - calm	ft.	830	1,010			
Take-off run at S.L. 17.5 kn. wind	ft.	480	600			
Take-off to clear 50 ft. - calm	ft.	--	--			
Max. speed/altitude	(A) kn./ft.	243/4,000	242/4,000			
Rate of climb at S.L.	(A) fpm	1,950	1,750			
Time: S.L. to 10,000 ft.	(A) min.	5.8	6.7			
Time: S.L. to	ft.	min.	--			
Service ceiling (100 fpm)	ft.	24,800	23,200			
Combat range	n.mi.	965	920			
Average cruising speed	kn.	145	145			
Cruising altitude(s)	ft.	5,000	5,000			
Combat radius	n.mi.					
Average cruising speed	kn.					
Mission time	hrs	6.4	6.0			
COMBAT LOADING CONDITION						
COMBAT WEIGHT	lb.					
Engine power						
Fuel	lb.					
Combat speed/combat altitude	kn./ft.					
Rate of climb/combat altitude	fpm/ft.					
Combat ceiling (500 fpm)	ft.					
Rate of climb at S.L.	fpm					
Max. speed at S.L.	kn.					
Max. speed/altitude	kn./ft.					
LANDING WEIGHT	lb.	19,988	21,771			
Fuel	lb.	312	312			
Stall speed - power-off	kn.	73.3	76.5			
Stall speed - with approach power	kn.	61.4	64.1			

NOTES

(A) Normal rated power.

PERFORMANCE BASIS: NATC and contractor's flight test data.

RANGE AND RADIUS are based on flight test fuel consumption data increased by 5%.

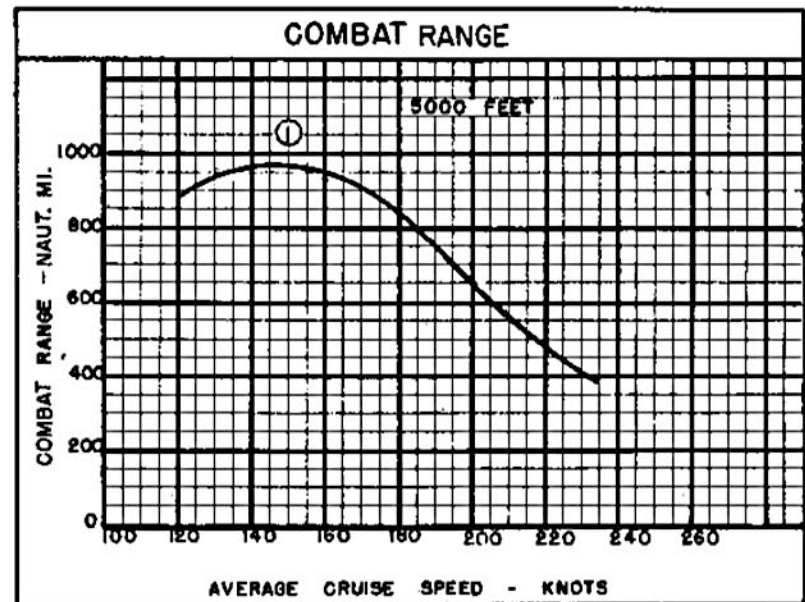
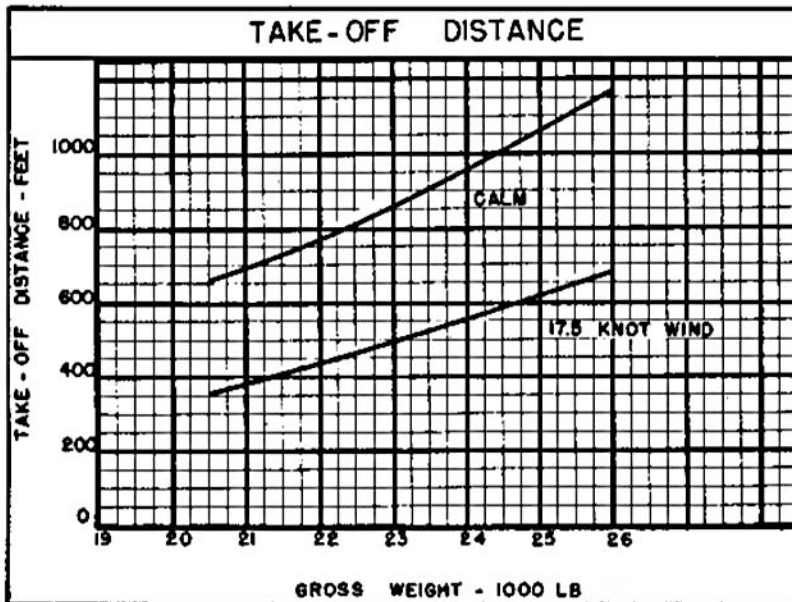
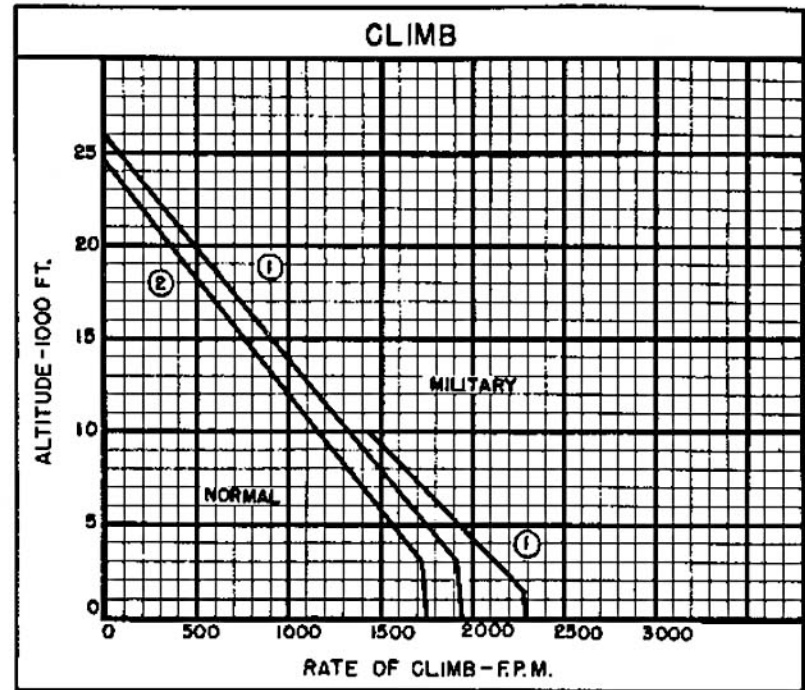
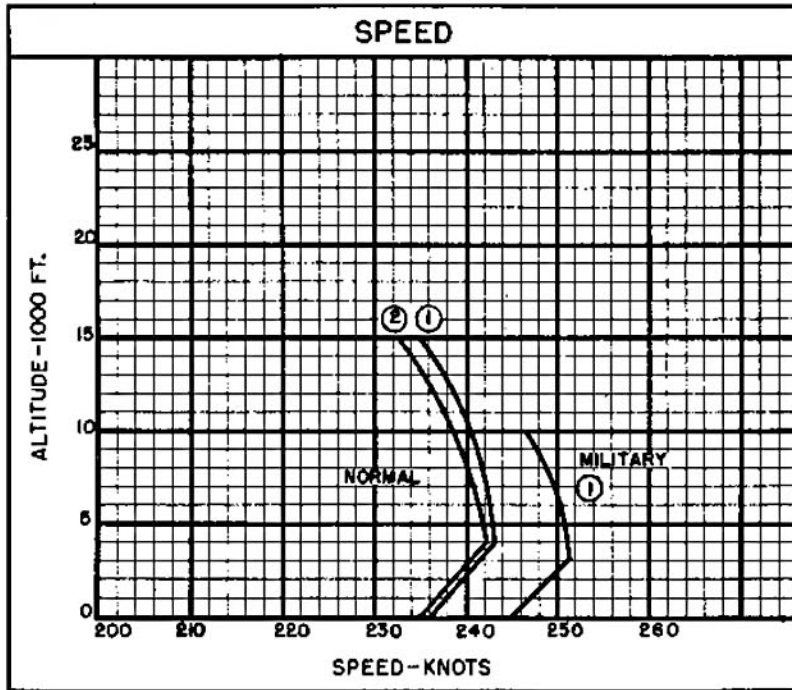

○ LOADING CONDITION COLUMN NUMBER

NOTES

SPOTTING: A total of 76 airplanes can be accommodated in a landing spot on the flight and hangar decks of a CVA-19 class angled deck carrier.

COMBAT RANGE AND ENDURANCE PROBLEM - CARGO AND TRANSPORT

WARM-UP, TAXI, TAKE-OFF: 10 minutes at normal rated power at sea level.

CLIMB: To 5,000 feet at normal rated power.

RANGE AND ENDURANCE: Cruise at best cruise speed for long range at 5,000 feet.

RESERVE: 5% of initial fuel load plus 30 minutes at speed for long range at sea level.

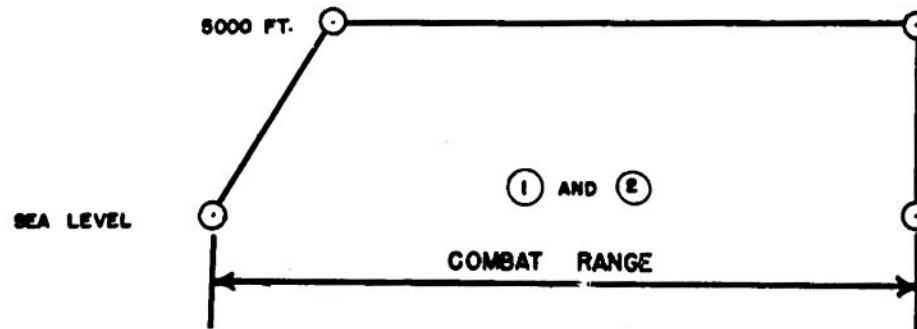

Combat Radius is 40 percent of combat range.



LOADING CONDITION COLUMN NUMBER